

# Original User Manual

# MAD



## 1. Introduction

Congratulations on your purchase of this battery torque wrench. This tool is specially designed for tightening, loosening and checking bolt connections. Make sure that each user has read the operating instructions carefully before using this torque wrench. This tool has been developed by M-PT to meet the needs of our customers. We are always open to and grateful for suggestions and ideas for improvement.

Please note: The images shown in the operating instructions may vary depending on the tool, the options that are activated and software version.

## 2. Table of contents

1.	Introduction	2
2.	Table of contents	2
3.	Manufacturer	4
4.	EC Declaration of Conformity	4
5.	Safety Instructions	5
5.1.	General safety instructions	5
5.2.	Security of employment	5
5.3.	Electrical safety	5
5.4.	Security of persons	5
5.5.	Security of the tool	5
6.	Scope Of Delivery	6
7.	Product Identification	6
8.	Technical Data	6
9.	Functional Description	6
9.1.	Start-up	6
9.2.	Preparing the wrench	7
9.3.	Operating the tool	7
9.4.	Start menu	8
9.4.1.	Setting the torque	8
9.4.2.	Setting the rotation angle	8
9.4.3.	Key lock	9
9.4.4.	Temperature monitoring	9
9.4.5.	Charge status of the battery	9
9.5.	Main menu	10
9.5.1.	Preset	10
9.5.2.	Statistic: Maintenance and life counter	10
9.5.3.	Information	11
9.5.4.	Diagnosis	11
9.5.5.	Extended menu	11
9.5.5.1.	Settings in the extended menu	12
9.5.5.1.1.	Activation of rotation angle	12
9.5.5.1.2.	Limit activation and setting	12
9.5.5.1.3.	Bolt counter activation and setting	13
9.5.5.1.4.	Setting lock activation	13
9.5.5.1.5.	CCW Cycle	13
9.5.5.1.6.	Scanner activation	13
9.5.5.1.7.	Point calibration	14
9.5.5.1.8.	Unit	15
9.5.5.1.9.	Language	15
9.5.5.1.10.	Back-off rotation angle	15
9.5.5.2.	Unlock further functions	16

9.5.5.3.	Data logging	16
9.5.5.3.1.	View log file	16
9.5.5.3.2.	Choose log file	17
9.5.5.3.3.	Date/Time	17
9.5.5.3.4.	Datatransfer	17
9.5.5.3.5.	Program selection	18
9.5.5.3.5.1.	Normal program (Norm)	18
9.5.5.3.5.2.	Check program (Check)	18
9.5.5.4.	Locking the extended menu	18
10.	Support of The Reaction Arm	19
11.	PC Software for The Documentation System	20
11.1.	Add the torque wrench as a bluetooth device at Windows	20
11.2.	Installing the software on Windows	20
11.3.	Setting up the software	20
11.4.	Reading out the data	20
11.5.	Saving and printing the data	20
11.6.	Synchronize the clock	20
12.	Troubleshooting	21
12.1.	Error message: „Overheating error“	21
12.2.	Error message: „Insert SD card“	21
12.3.	Error message: „Zero point“	21
12.4.	Error: Only dashes appear on the display instead of letters	21
12.5.	Error: Incorrect date and time	21
12.6.	Error: Cannot set minimum or maximum torque	21
12.7.	Error: Tool is not responding to buttons	21
12.8.	Error: Button is pressed, but tool does not rotate	21
12.9.	Error: Tool does not loosen the bolts in counter-clockwise rotation	21
12.10.	Error: Tool displays error message after bolted connection	21
13.	Accessories	22
13.1.	Tool holder	22
13.2.	Extensions	22
13.3.	Sockets and locking devices	22
14.	Disclaimer	22
15.	Maintenance and Service	22
15.1.	General information	22
15.2.	Visual inspection	22
15.3.	Service intervals	22
15.4.	Repair bridge	22
15.5.	Calibration	23
15.6.	Contact for maintenance and repairs	23
16.	Product Overview	24

### 3. Manufacturer



M-PT Matjeschk-PowerTools GmbH & Co. KG  
Am Sägewerk 11  
01920 Ralbitz-Rosenthal, Germany  
Tel.: +49 (0) 35 796 / 9760  
mail@m-pt.de

### 4. EC Declaration of Conformity

We M-PT Matjeschk-PowerTools GmbH & Co. KG  
Am Sägewerk 11  
01920 Ralbitz-Rosenthal, Germany

declare in sole responsibility that the product

Machine: Battery-powered torque wrench  
Series: MAD

which refers this declaration, is conform with the following standards or normative documents:

- DIN EN 300328:2019-10
- DIN EN 301489-1:2020-06
- DIN EN 301489-17:2021-03
- DIN EN 301489-19:2023-02
- DIN EN 303413:2021-07
- DIN EN 50360 VDE 0848-360:2019-03
- DIN EN 50566 VDE 0848-566:2019-04
- DIN EN 50663 VDE 0848-663:2019-04
- DIN EN IEC 55014-1 VDE 0875-14-1:2022-12
- DIN EN IEC 55014-2 VDE 0875-14-2:2022-10
- DIN EN IEC 61000-3-2 VDE 0838-2:2023-10
- DIN EN 62479 VDE 0848-479:2011-09
- DIN EN 62841-1 VDE 0740-1:2023-03
- DIN EN 62841-2-2 VDE 0740-2-2 Berichtigung 1:2017-07

in accordance with the guidelines: 2006/42/EG, appendix II A  
2011/65/EU  
2014/30/EU  
2014/53/EU

Ralbitz-Rosenthal, 12.08.2024

## 5. Safety Instructions

### 5.1. General safety instructions

- The safety of the operator and the trouble-free operation of the machine can only be guaranteed if original M-PT components are used. This applies to all parts, accessories and spare parts. If other components are used, M-PT cannot guarantee safe operation and function.

### 5.2. Security of employment

- Keep your work area clean and well lit.
- Do not use the tool in potentially explosive atmospheres containing flammable liquids, gases or dusts. Electronic tools produce sparks which can ignite dust or vapors.
- Observe laws and regulations at the place of use.

### 5.3. Electrical safety

- Only use the battery supplied or an identical one with the same technical characteristics. Do not modify the battery in any way.
- Keep the tool away from rain and wetness.
- If use in wet conditions is unavoidable, protect the wrench and battery from moisture. For suitable protective covers, please contact the 24/7 M-PT Service (tel. +49 (0)35796/9760).

### 5.4. Security of persons

- Keep children and other people away when using the tool. You may lose control of the tool if you are distracted.
- Keep unused tools out of the reach of children.
- Do not allow anyone to use the tool who is unfamiliar with it or who has not read these instructions.
- Wear personal protective equipment:



### 5.5. Security of the tool

- Check the tools for obvious damage before use.
- Do not use damaged tools.
- Repair any damage before use.
- Do not use a battery tool if the switch is defective.
- Disconnect the battery from the tool before changing accessories or putting the tool away.
- Let the tool be repaired by qualified specialists using only original parts.

## 6. Scope Of Delivery

- Battery torque wrench
- Reaction arm with retaining ring
- 2 pieces Li-Ion batteries 5,2 Ah/18 V or 8,0 Ah
- Battery charger
- Calibration certificate
- User manual with EC Declaration of Conformity
- Tool case

## 7. Product Identification

The product name and serial number can be found on the type plate. The battery must be removed from the torque wrench.



## 8. Technical Data

See type plate and calibration certificate.

## 9. Functional Description

### 9.1. Start-up

- The torque wrench is supplied ready for use.
- Only use components and accessories that do not affect the function and safety of the torque wrench.
- Observe the battery voltage specified on the type plate.

### 9.2. Preparing the wrench

- Place the reaction arm (2) on the gearing of the torque wrench (1).
- Secure the reaction arm by inserting the retaining ring (3) into the groove on the wrench gear.
- Fit the socket (4) onto the square drive of the torque wrench. Only use sockets with a standardized square drive according to DIN 3121.
- Secure the socket with a pin (5).
- Secure the pin with a locking ring (6) to prevent it from falling out.

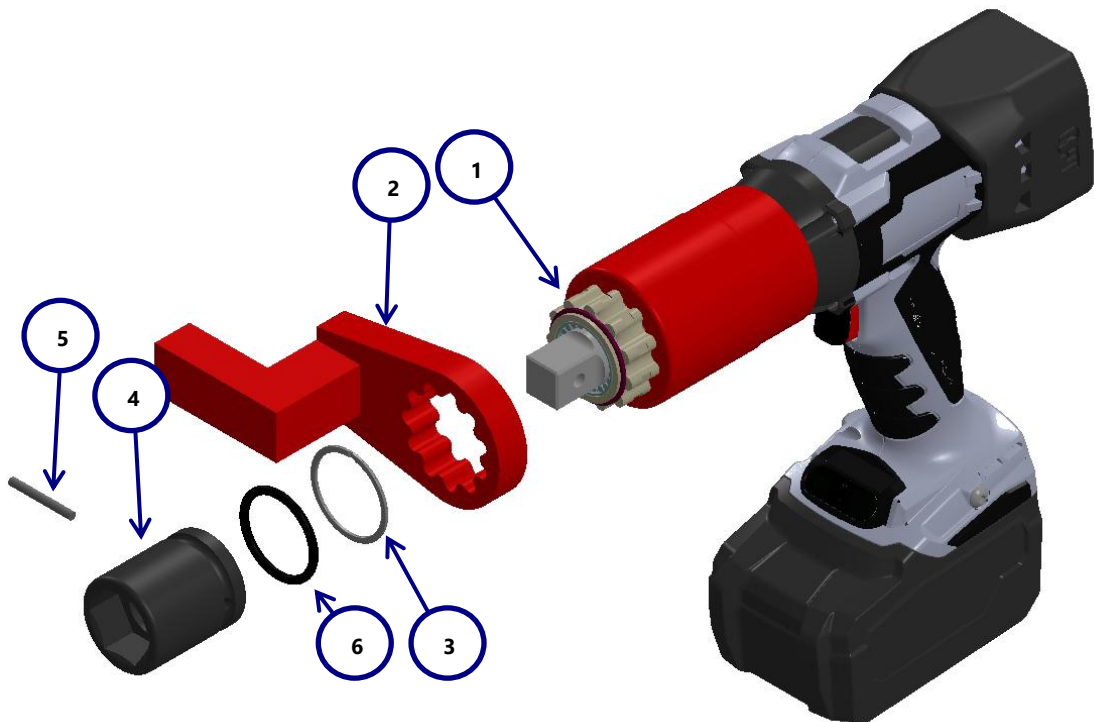

### 9.3. Operating the tool

- Settings are made using the following buttons:
  - Main button (M)
  - Button PLUS (+)
  - Button MINUS (-)
- The direction of rotation is set on the changeover switch.
- Start operating with the trigger.
- The following menus are used for settings:

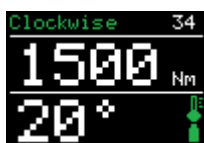
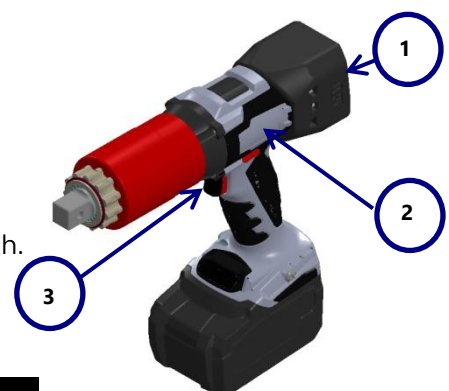

Start menu

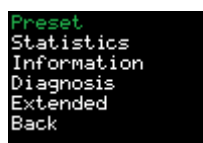

Main menu

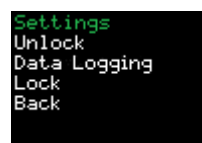

Extended menu

### 9.4. Start menu

- The tool switches on when the battery is attached. A short automatic function test is performed. If the test shows errors with NOK, please contact 24/7 M-PT Service (tel. +49 (0) 35796/9760).



- The start menu will then open.
- If the torque wrench has been purchased with a documentation system, the display will briefly show the date, time and file name of the open log file for the Documentation System. After checking the data is correct, confirm the information by briefly pressing the button. The start menu will now also open.



- The torque and rotation angle values can be set in the start menu. If additional settings have been selected in the extended menu (see section 9.5.5), these values will also be requested in sequence in the start menu.
- The tool type is shown at the top right of the display (e.g. „40” for MAD 4000).
- The set direction of rotation can be read at the top left (clockwise or counter-clockwise).
- The current status of the tool temperature (see section 9.4.4) and the battery charge status (see section 9.4.5) are displayed at the bottom right.
- If the torque wrench is not used for a while in the start menu, the display switches off after 60 seconds.

#### 9.4.1. Setting the torque



- When switching on, the torque wrench displays the last torque setting.
- The factory setting is 0 Nm.
- Briefly press the main button to activate the torque setting. The torque value is now displayed in orange.
- The value can be changed by using the + and - buttons. This value is confirmed with the main button and the stored torque is displayed in white.
- After tightening, the actual torque is shown on the display for 10 seconds.
- If the torque is NOK, the display will show the torque value in red. The error can be acknowledged with any button.

#### 9.4.2. Setting the rotation angle

- To set the rotation angle it has to be activated in the extended menu (see section 9.5).



- Once the torque has been set, one is automatically taken to the value of rotation angle. This value is shown in orange.
- The value can be changed using the **+** and **-** buttons. This value is confirmed with the main button and the stored rotation angle is displayed in white.
- The value of rotation angle can be set between 0° and 360°.
- If the final torque in the torque/rotation angle mode is greater than the maximum allowable torque for the wrench's gearbox, the wrench will automatically stop for safety reasons (for technical data see section 8).

#### 9.4.3. Key lock

- The key lock is activated or deactivated by pushing the main button and the **+** button for 3 sec. simultaneously.
- When the keypad is locked, a small key appears on the display. Torque and rotation angle adjustment is no longer possible.
- The torque wrench still works according to the previously set values when the key lock is active.

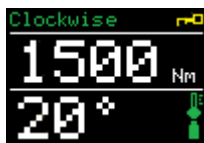

#### 9.4.4. Temperature monitoring

- The temperature is constantly measured inside the torque wrench and is always displayed on the start menu as a thermometer icon in the bottom right-hand corner of the display.
- Due to various reasons the torque wrench could heat-up during bolt assembly, e.g. assembly in extremely high ambient temperatures, material damage to the bolt set, incorrect tightening procedure, etc.
- The torque wrench automatically switches to EMERGENCY STOP when the thermometer symbol reaches the red zone, to protect the tool from permanent damage.
- The icon display options are defined as follows:
  - Green thermometer  
Temperature below 50 % of the maximum allowed temperature
  - Yellow thermometer  
Temperature between 50 % and 80 % of the maximum allowed temperature
  - Red thermometer  
Temperature above 80 % of the maximum allowed temperature
- As soon as the engine temperature reaches 120°C, a further written warning appears on the display.

#### 9.4.5. Charge status of the battery

- Tightening by torque or rotation angle with defined repeatability is only guaranteed if the battery is in good condition. The battery symbol in the bottom right-hand corner of the start menu is used for monitoring.
- The tool automatically switches to EMERGENCY STOP when the battery symbol reaches the red area to prevent incorrect assembly.
- The icon display options are defined as follows:
  - Green battery  
Charge status above 50 % of the maximum charge capacity
  - Yellow battery  
Charge status between 20 % and 50 % of the maximum charge capacity
  - Red battery  
Charge status below 20 % of the maximum charge capacity
- If the charge level is below 20 %, a further written warning appears on the display.

### 9.5. Main menu

- Press and hold the main button for 3 sec. to access the main menu from the start menu.
- The main menu contains the following information and settings:
  - Preset
  - Statistics
  - Information
  - Diagnosis
  - Extended

#### 9.5.1. Preset

- The tool can save up to 20 customer presets.
- In addition, six HV-presets from M16 – M30 are already pre-defined.

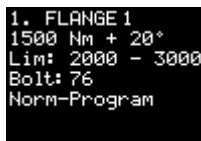
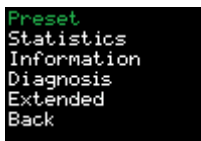

- The customer preset displays as follows:
  - Consecutive number and name of the preset
  - Torque and rotation angle
  - Defined tolerance of the limits
  - Set limits (Lim) of lower limit value - upper limit value
  - Number of bolts according to the bolt counter
  - Selected program (Norm resp. Check)
  - Set back-off rotation angle („B“ for back-off)
- Use the + and - buttons to select between the saved presets.
- Press and hold the main button to open the following submenu:

- **Accept:** Applies the selected preset to the start menu.
- **Overwrite:** The torque/rotation angle values set in the start menu will be saved in this preset.
- **Cancel:** Exit from this submenu.
- **Back:** This command returns to the preselection menu (Customer Preset and HV Preset).



- HV presets can only be selected and not overwritten. These are displayed according to the permissible torque range of the respective torque wrench.
- The preset tightening torques for HV bolts refer to the modified torque method according to DIN EN 1993-1-8 for k-class K1.

#### 9.5.2. Statistic: Maintenance and life counter

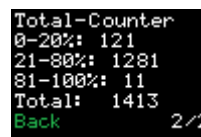
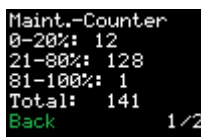
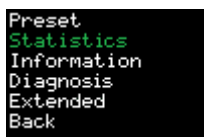

- In the main menu under „Statistics“ the maintenance and life counters are stored.
- The maintenance counter indicates the number of tightening since the last maintenance (menu page 1/2).
- The life counter indicates the number of all bolt connections with this tool (menu page 2/2).
- Using the + and - buttons one can switch between the two menu pages.

- The counters are divided into:
  - **0 - 20 %**  
Number of bolts in the range 0 - 20 % of the max. torque
  - **21 - 80 %**  
Number of bolts in the range 21 - 80 % of the max. torque
  - **81 - 100 %**  
Number of bolts in the range 81 - 100 % of the max. torque
  - **Total:**  
Total number of bolts
- After a total number of 20.000 bolt connections, the message „Schedule maintenance” appears on the display when the tool is switched on.

### 9.5.3. Information



- The following data is displayed under the „Information“ menu:
  - Version number of the current software
  - Serial number of the tool
  - 24/7 M-PT Service phone number
  - Website of the manufacturer

### 9.5.4. Diagnosis

- This menu is only used by our M-PT Service for remote diagnosis by phone.
- It contains the following information:
  - Mains: current battery voltage
  - InP: Input diagnostics field for the trigger and direction of rotation
  - Status: Current utilization until next maintenance.  
At 100%, the torque wrench is due for maintenance.
  - Temp-A: current temperature in the battery
  - Temp-M: current temperature in the motor
  - Temp-I: current temperature in the control electronics
  - GPS longitude coordinates (NO GPS, if no range)
  - GPS latitude coordinates (NO GPS, if no range)
- Use the **+** and **-** buttons to switch between the two menu pages (1/2 or 2/2).

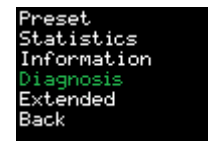

### 9.5.5. Extended menu

- The extended menu can be activated using the password **17580**.  
With the **+** and **-** buttons the desired digit can be selected. The main button is used to move to the next digit.

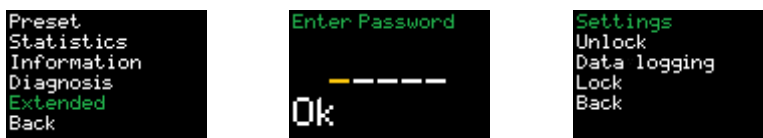

- This password must be re-entered when the battery is removed from the torque wrench. If the torque wrench remains in use, the extended menu can be specifically locked and a new password request will appear.

- The following settings can be made in the extended menu:
  - Settings:
    - Activating/ deactivating functions (menu page 1/2)
      - Rotation Angle
      - Limits
      - Bolt Counter
      - Setting Lock
      - CCW Cycle
      - Scanner
    - Perform or change parameters (menu page 2/2)
      - Point Calibr.
      - Unit
      - Language
      - Back-Off
  - Unlock
  - Data Logging
  - Lock

**9.5.5.1. Settings in the extended menu**

- Functions are activated and deactivated using the main button. Activated functions are marked with a green tick in this menu; deactivated functions with a red cross.

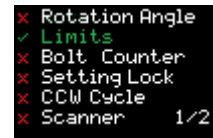

**9.5.5.1.1. Activation of rotation angle**

- The rotation angle must be activated, if the bolt tightening has to be carried out via torque/rotation angle method. Entering the TARGET rotation angle is explained in section 9.4.2.
- If the rotation angle is deactivated, only the TARGET torque must be entered in the start menu and will be shown on the display.

**9.5.5.1.2. Limit activation and setting**

- For torque/rotation angle tightening, limits can be defined for the final torque.
- When tightening by torque only, the limits are defined in rotation angular degrees. Rotation angle counting starts when the minimum torque of the specific torque wrench is reached.
- In the case of tightening by rotation angle only, after the joint has been pre-tightened, the limits are defined in torque.
- The limits are set in the start menu after entering the TARGET torque and rotation angle (see section 9.4.1).

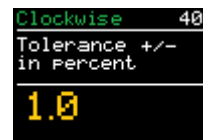
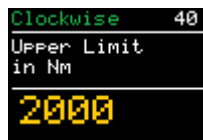
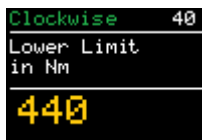

- Beside of the limit values it is also possible to define a permissible tolerance for the set shut-off value.
- If the limit values are exceeded or undercut during tightening, the message appears in red on the display, together with the ACTUAL torque and rotation angle values. The message must be actively confirmed by the operator by pressing any button.



### 9.5.5.13. Bolt counter activation and setting

- The bolt counter is a good way of self-monitoring assembly work with the torque wrench. If the job consists of a large number of bolt connections, the operator is guided through the assembly process.
- The bolt counter is activated in the extended menu on menu page 1/2.

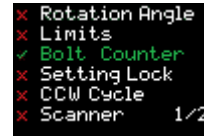
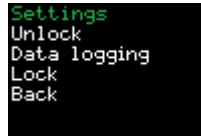
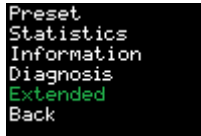

- The total number of bolt connections for each job is entered in the start menu after entering the TARGET torque and rotation angle values (see section 9.4.1).
- The bolt counter can be defined with a number of bolts between 1 and 999.
- All completed OK tightening operations in a clockwise direction are counted there.
- When all the bolts have been fully tightened, the tool locks to indicate that the job has been completed. The operator can proceed as follows:
  - Set the number of bolts for a new job
  - Deactivate the bolt counter when it is no longer required
- If the battery is removed from the torque wrench before the job is finished, the bolt counter will continue counting at the same bolt.
- To prevent bolts from being counted twice by tightening an already tightened bolt a second time, the counter should be used in combination with the limit value setting (see section 9.5.5.12). In the case of torque tightening, the lower test rotation angle can be set to 10°, for example.

### 9.5.5.14. Setting lock activation

- The setting lock is activated and deactivated in the extended menu on menu page 1/2.
- If the setting lock is active, the torque cannot be adjusted.
- Only torques from the preset menu can be selected (see section 9.5.1).

### 9.5.5.15. CCW Cycle

- The counter-clockwise (CCW) Cycle allows the torque wrench to be used for bolt connections where precise torque/rotation angle shut-off is also required in counter-clockwise rotation. This applies for defined loosening of bolted connections.
- In addition, the CCW Cycle can be used to tighten counter-clockwise threaded bolts to a defined torque.
- CCW Cycle is activated and deactivated in the extended settings under Extended → Settings → CCW Cycle.
- If the CCW Cycle is activated, it is marked with a green tick; the deactivated function whereas with a red cross.

### 9.5.5.16. Scanner activation

- The extended menu offers the option of integrating a commercial hand-held scanner. Communication between the scanner and torque wrench takes place via a Bluetooth connection. For example, a production line can be equipped with QR codes or barcodes containing information on TARGET torque, rotation angle, limit setting, bolt counter, etc. Tightening data is captured by the scanner and automatically transmitted to the torque wrench. It is no longer necessary to enter the TARGET values on the torque wrench. The process reliability will be increased. Other applications include maintenance of bolts in wind turbines or the inspection of gate valves in water or gas supply systems.

- The purchase of an M-PT hand scanner is accompanied by a separate, detailed operation instruction.
- If the operator already has scanners, the technical requirements for compatibility with the torque wrench must be checked. Please contact our 24/7 M-PT Service (tel. +49 (0)35796/9760) to pair your own scanner with the torque wrench.

#### 9.5.5.1.7. Point calibration

- With point calibration the accuracy of the torque wrench can be calibrated to the specific application by correcting deviations for onsite conditions.
- An external transducer is required to measure the actual values such as torque or rotation angle. For this purpose we recommend using the Smart Socket™ - a socket with an integrated transducer.
- First enter the TARGET torque/ rotation angle in the start menu.
- The point calibration is then selected and started in the extended menu under „Settings” on menu page 2/2.

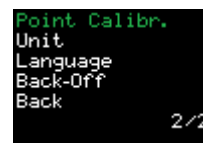
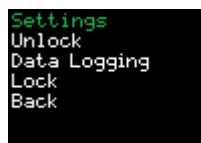
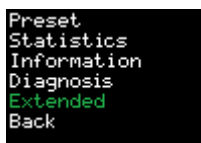

#### 1. Bolt Perform

- Point calibration starts at the first bolt connection. The display will show the command „1. Bolt Perform“. The torque wrench is now placed on the respective bolt connection and the bolt is tightened. The ACTUAL torque achieved is read from the external transducer (e.g. the Smart Socket™).
- This value has to be entered on the torque wrench display. Press the main button to activate the torque setting. The value will turn orange and can be changed using the **+** and **-** buttons. The value is confirmed again with the main button, i.e. it turns green. When the main button is pressed again, the torque value on the display turns orange again and can be changed using **+** and **-** buttons.
- The 1. Bolt Perform is completed by pressing the **-** button. The value must be shown in green.  
The point calibration can be cancelled by pressing the **+** button.

#### 2. Bolt Perform

- In the following a second bolt tightening is requested. The command „2. Bolt Perform” appears on the display. The torque wrench is now placed on the appropriate bolt connection and the bolt is tightened. The ACTUAL torque achieved is read from the external transducer (e.g. the Smart Socket™).
- This value should now be entered on the torque wrench display. Press the main button to activate the torque setting. The value will turn orange and can be changed using the **+** and **-** buttons. The value is confirmed again with the main button, i.e. it turns green. When the main button is pressed again, the torque value on the display turns orange again and can be changed using **+** and **-** buttons
- The 2. Bolt Perform is completed by pressing the **-** button. The value must be shown in green.  
Press the **+** button to go back one step, i.e. to the 1. Bolt Perform.

#### Saving the point calibration

- After the 2. Bolt Perform the word „Save” appears on the display. If the point calibration is to be accepted, it must be confirmed with the main button. With the button **+** it is possible to go back one step, i.e. to the 2. Bolt Perform, and with button **-** one can cancel the point calibration.

- The point calibration can also be saved in the presets (see section **Fehler! V erweisquelle konnte nicht gefunden werden.**).

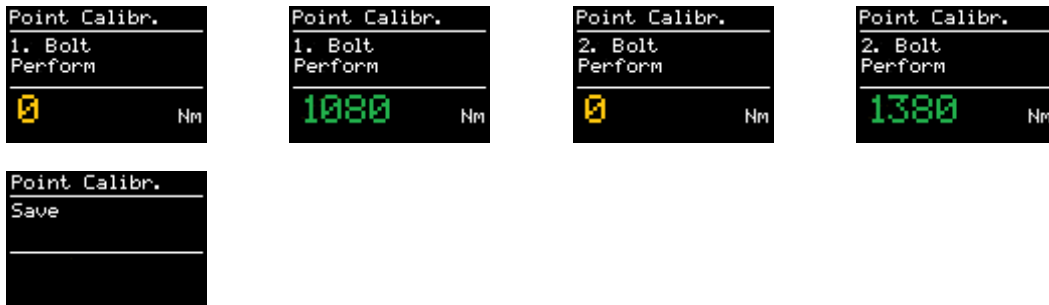

#### 9.5.5.18. Unit

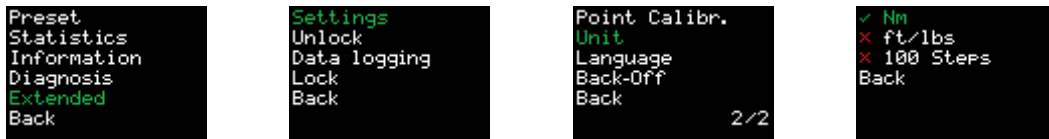

- The torque unit can be set in the extended menu on page 2/2. The selection is made with the main button, marked by a green tick in front.
- The following torque units can be selected:
  - Nm ... Newtonmeter
  - Ft/lbs ... Foot-pound
  - 100 steps ... 100 setting steps
- If the units get changed, the calibration values in the torque wrench are adjusted automatically. It is not necessary to recalibrate the torque wrench.
- If you want to work in step mode a torque table is required. This can be requested at M-PT.

#### 9.5.5.19. Language



- In the extended settings on menu page 2/2 one can choose between 5 languages:
  - Deutsch
  - English
  - Espanol
  - Francais
  - Nederlands
- After changing the language, the torque wrench restarts automatically.

#### 9.5.5.10. Back-off rotation angle

- In the extended menu on page 2/2 the back-off rotation angle can be set continuously from 0-360°. The setting is activated with the main button. As soon as the value is displayed in orange, the value can be changed with the + and - buttons. The value is confirmed by pressing the main button again so that it is displayed in green. The word „Save” appears when the + or - button is pressed. This must then be confirmed with the main button.
- The back-off rotation angle is factory set to 10°.

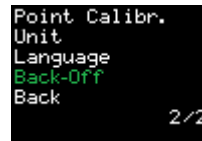
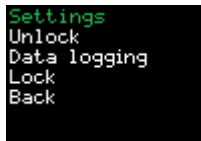
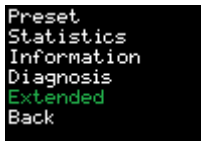

- As soon as a load greater than the minimum torque value is reached, the tool rotates back in the opposite direction. After a successful tightening operation, the torque wrench rotates back by the set back-off rotation angle. It may be necessary to adjust the back-off rotation angle if the application is a very soft or hard joint. In addition, there are applications with special, customized reaction arms and other accessories that require an adjustment of the back-off rotation angle.
- For safety reasons, if a torque is detected during load release, e.g. when driving against an obstacle, the back-off will stop immediately.

### 9.5.5.2. Unlock further functions

- The torque wrench can be configured with additional functions and software connections. These include:
  - the Torque Check Function
  - the Documentation System
  - the activation of BoltPilot®, PG (CSP) or ProTight™
- If these are purchased with a new tool, the functions are already activated on the torque wrench.
- However, it is still possible to purchase additional functions at a later date after the purchase of a new tool. The Documentation System and activation of the BoltPilot®, PG (CSP) and ProTight™ software can be done remote via phone. Call the 24/7 M-PT Service (tel. +49 (0)35796/9760) for activation. Start your torque wrench and go to the extended menu until you reach the „Unlock“ submenu. Via phone call to M-PT Service the next steps will be explained.
- To activate the Torque Check Function the torque wrench must be sent to M-PT.

### 9.5.5.3. Data logging

- If the Documentation System has been purchased this function can be found in the extended menu as „Data logging“. Otherwise, the Documentation System can also be purchased and activated at a later time.

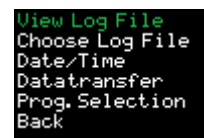
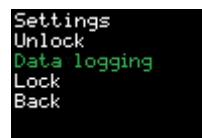
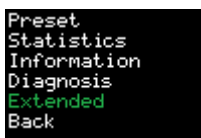

- Alternatively, you can navigate directly to the submenu „Data logging“ from the start menu. Press both the + and - buttons simultaneously until the submenu opens.
- The data logging menu consists of following submenus:
  - View Log File
  - Choose Log File
  - Date/Time
  - Datatransfer
  - Prog.Selection
 This menu only appears if the Torque Check Function is purchased. Otherwise it can also be purchased and activated later on (see section 9.5.5.2).

#### 9.5.5.3.1. View log file

- In this submenu all bolting data can be viewed on the torque wrench, directly. Press and hold the buttons + or - for 3 sec. to switch between the saved bolting operations.

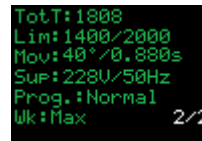
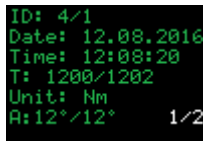
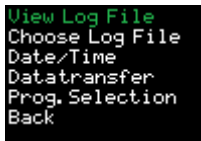

The colors of the displayed values indicate the status of the specific tightening job:  
 Green = OK (tightening process okay)  
 Red = NOK (tightening process not okay)  
 Orange = Counter-clockwise rotation (tightening process when loosening)

- These data are following on menu page 1/2:
  - ID ... Consecutive number (for each tightening cycle from the minimum torque of the tool)
  - Date ... Date at tightening
  - Time ... Time at tightening
  - T: xx/xx ... Torque TARGET/ACTUAL
  - Unit: ... Set unit
  - A: xx°/xx° ... Rotation angle TARGET/ACTUAL
- To access menu page 2/2, press and hold the **-** button:
  - TotT: ... Total torque
  - Lim: ... Set limits
  - Mov: ... Total rotation angle and bolting time
  - Sup: ... Voltage of the battery
  - Prog.: ... Program selection
  - Wk: ... Worker

**9.5.5.3.2. Choose log file**

- All log files created can be selected here by entering the saved file name. This log file will then be used and continued with subsequent bolting data.
- A new log file can also be created in this submenu by entering a new file name and saving it.
- The entry is cancelled by pressing and holding the main button.
- A blank entry cannot be saved. In this case the last file is automatically continued.

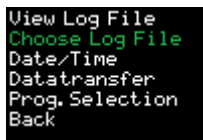
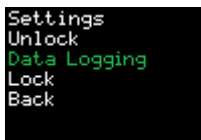

**9.5.5.3.3. Date/Time**

- This submenu displays the date and current time. If these are incorrect, the date and time must be updated on the PC using the associated „Documentation System” software. The data is transferred from the PC and synchronized. Regular monitoring is essential to ensure that the bolting data is correctly archived in the data logging.

**9.5.5.3.4. Datatransfer**

- The submenu „Datatransfer” is used to export the bolting data to a PC. For this the software application „Documentation System” must be started on the PC before.
- Furthermore, the Worker ID can be activated or deactivated in this submenu. If the option is activated, an 8-digit worker ID is assigned when the tool is switched on. This will be included to the data logging.
- Alternatively, one can navigate directly to the „Datatransfer” submenu from the start menu. To do this press the **+** and **-** buttons simultaneously until the submenu opens.

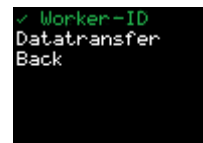
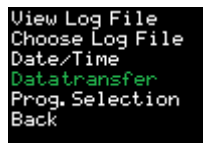
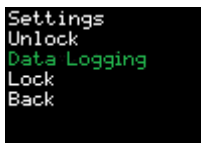

### 9.5.5.3.5. Program selection

- Once the Torque Check Function or Documentation System is purchased, one can choose between the normal program and the check program. These functions can also be purchased subsequently at any time. M-PT is pleased to advise you!

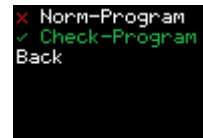
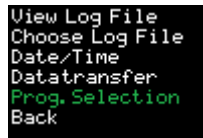
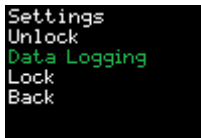

- Alternatively, one can navigate directly to the „Program selection” submenu from the start menu. To do this press the + and - buttons simultaneously until the submenu opens.

#### 9.5.5.3.5.1. Normal program (Norm)

- The normal program must be selected as standard to assemble or disassemble bolted connections.

#### 9.5.5.3.5.2. Check program (Check)

- The torque check program must be used and activated when checking the tightness of bolted connection. This mode allows the torque wrench to be placed on a bolted connection that has already been tightened. The conditions for further tightening are defined in DIN EN 1090-2.
- When the check program is activated the display in the start menu alternates between „Check” and the set torque value.
- As the trigger is pulled in clockwise direction, the torque wrench will slowly apply the reaction arm. It will carefully approach the torque to be checked.
- If the actual torque on the bolt is less than the target torque to be checked, the torque wrench will re-torque the bolt to the set target torque, automatically.
- When the process is completed, the applied further rotation angle is displayed. As soon as the limits have been activated in the extended menu (see section 9.5.5.1.2), the torque wrench evaluates the further rotation angle.
- If the further rotation angle is outside defined limits, the display turns red and indicates which limit has been reached, the upper or lower limit. This message must be actively confirmed by pressing any button.



- If the further rotation angle is within the set limits, the display turns green and the respective further rotation angle is shown.
- Due to the elastic deformation of the reaction arm a further rotation angle of approx. 1-3° is also displayed for already tightened bolts. This must be determined at the start of the torque check and taken into account at the evaluation.

#### 9.5.5.4. Locking the extended menu

- In this submenu it is possible to lock the extended menu once the torque wrench has been set. To access this submenu the password must be entered again (see section 9.5.5). It is therefore up to the supervisor to decide which operators will be given the relevant password.

## 10. Support of The Reaction Arm

The correct design and construction of the reaction arm for each individual bolting operation is essential to achieve perfect force application to the threaded joint. This is the only way to guarantee the accuracy and faultless execution of the assembly work in the interaction between the fastening tool, reaction arm and socket.

Contact our 24/7 M-PT Service (tel. +49 (0)35796/9760) for a quick and uncomplicated advice, including analysis of your bolted connections!

Height of reaction arm:

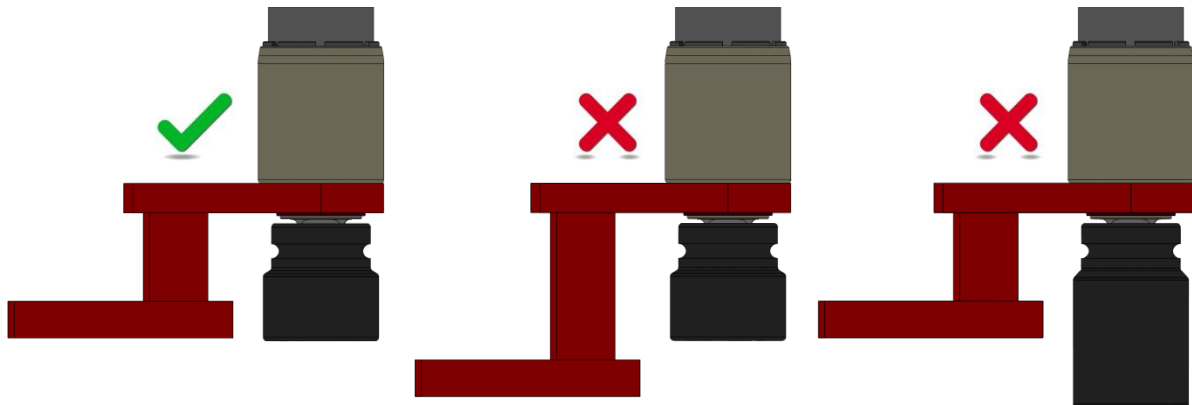

Overlay of reaction arm:

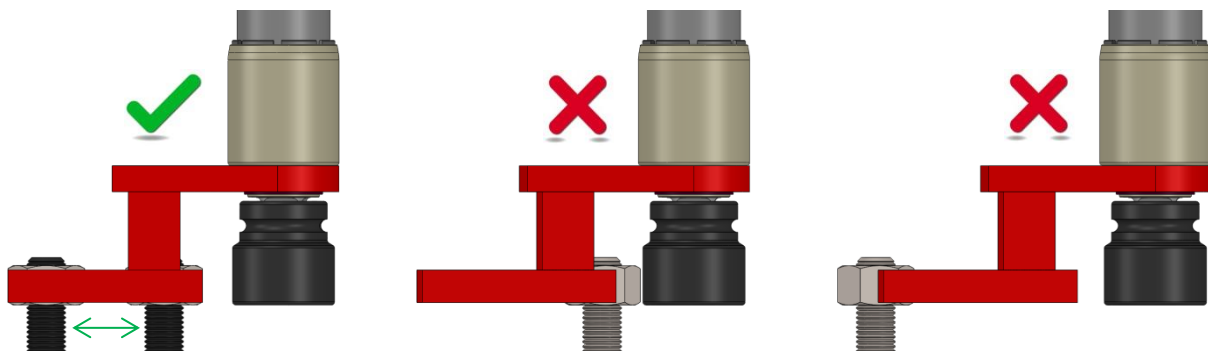

Danger of crushing:

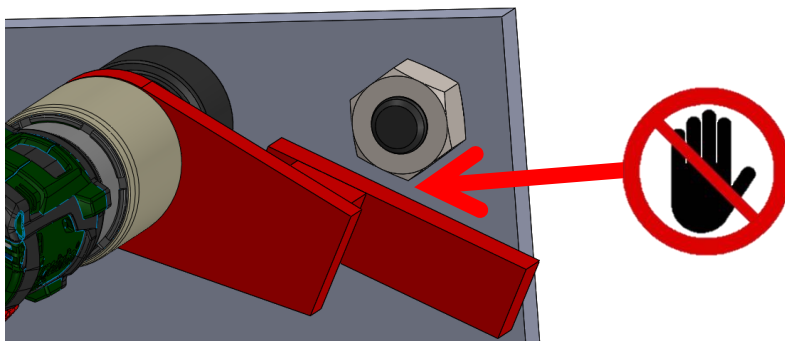

## 11. PC Software for The Documentation System

### 11.1. Add the torque wrench as a bluetooth device at Windows

1. Install the supplied bluetooth stick.
2. Activate the data connection on your torque wrench. To do this, go to the main menu Extended → Data logging → Datatransfer → Datatransfer.
3. Select on the PC at the start menu „Devices and printers“.
4. Select „Add device“.
5. Select the serial number of the torque wrench (e.g. MAD-M123456).
6. Click „Next“.
7. When the torque wrench has been successfully added, click „Close“.
8. Now right-click on the serial number of the torque wrench in the window „Devices and printers“.
9. Select „Properties“.
10. Select the tab „Hardware“.
11. You will find the corresponding COM port in the name of the bluetooth connection (e.g. „COM11“).
12. Close all windows.

### 11.2. Installing the software on Windows

13. Install the software by starting „setup.exe“.
14. Confirm the license conditions and click on „Next“.
15. Select an installation location and click on „Next“.
16. When the installation is complete click „Close“.
17. Close the data connection on your device by clicking „Back“.

### 11.3. Setting up the software

1. Open the software MAD Documentation System from the link on your desktop.
2. At „Select Port“ select the COM that you have identified in 11.1 (e.g. „COM11“).

### 11.4. Reading out the data

- Activate the data connection on your wrench. To do this, go to the menu → Extended → Data logging → Datatransfer → Datatransfer.
- Click on „Load data“.
- If you are selecting the torque wrench for the first time, enter your own name for the torque wrench. This can be an inventory number or any other name.
- Confirm with „Save“.
- If you are loading a new file, enter your own name for it. E.g. system or order number.
- Confirm with „Save“.
- The progress of the download is shown at the bottom left of the screen. Approx. 3 records will be downloaded per second.
- When the download is complete the wrench and the file can be selected at the top left of the screen.
- The name of the torque wrench and the file will appear, along with a table of the data recorded.

### 11.5. Saving and printing the data

- To print, select „Print“ from the menu tab.
- To save as PDF select a PDF printer at the print menu. A free PDF printer is provided on the installation USB stick.
- To save as .csv or .xlsx file select the „Export“ from the menu tab, then select the corresponding file extension.

### 11.6. Synchronize the clock

- Activate the data connection on the torque wrench. Go to the menu Extended → Data logging → Datatransfer → Datatransfer.
- Under the menu tab select the „Synchronize Clock“ entry.

## 12. Troubleshooting

If you cannot solve a problem using the following troubleshooting, please contact the 24/7 M-PT Service (tel. +49 (0)35796/9760) for a quick and uncomplicated support!

### 12.1. Error message: „Overheating error“

Cause: The motor, battery or control electronics are too hot. Allow the tool to cool down.

### 12.2. Error message: „Insert SD card“

Cause: The SD card is not recognized.

### 12.3. Error message: „Zero point“

Cause: When switching on the MAD, the gearbox is tensioned. Turn the tool counter-clockwise to relieve the gearbox.

### 12.4. Error: Only dashes appear on the display instead of letters

Cause: The SD card is not recognized.

### 12.5. Error: Incorrect date and time

Possible causes of error:

- The tool is in another time zone.
- The internal battery is empty.

### 12.6. Error: Cannot set minimum or maximum torque

Possible causes of error:

- Incorrect calibration
- Faulty internal memory

### 12.7. Error: Tool is not responding to buttons

Possible causes of error:

- Internal software error. The tool must be restarted.
- Membrane keypad defective.

### 12.8. Error: Button is pressed, but tool does not rotate

Possible causes of error:

- Torque set to 0 Nm.
- Bolt counter activated and set to 0.
- Bolt counter activated and all bolt connections completed.
- Trigger is defective.

### 12.9. Error: Tool does not loosen the bolts in counter-clockwise rotation

Possible causes of error:

- The torque required is higher than the maximum torque of the tool.
- Defective right/left switch.

### 12.10. Error: Tool displays error message after bolted connection

Possible causes of error:

- Limits are active and set incorrectly.
- Limits are active and tolerance is set incorrectly.
- Bolt has been overtightened, e.g. when retightening a fixed connection.
- The torque wrench has reached its maximum torque when tightening the rotation angle. To protect the gearbox, the wrench will automatically stop and return an error message.
- The trigger was released before the tool was shut off.

## 13. Accessories

### 13.1. Tool holder

To make work easier, there are holders for all tools. These are attached to the gearbox. This allows the tools to be suspended from a balancer. Please contact M-PT for the correct suspension.

### 13.2. Extensions

Extensions are needed to get into tight places, such as deep wheel hubs. These are available in different lengths for all tools. Ask M-PT for advice.

### 13.3. Sockets and locking devices

Sockets and reaction arms must be suitable to each other. To obtain an optimized system, contact M-PT for the sockets and locking devices.



## 14. Disclaimer

This operation instruction has been compiled with the utmost care. However, should you notice any omissions or inaccuracies, please contact us at the address given. M-PT accepts no liability for technical or typographical errors and reserves the right to make changes to the product and operating instructions at any time without prior notice. M-PT shall not be liable or responsible for any direct or indirect consequential damage arising from the use of this product. No guarantee is given for the contents of this document.

Damage caused by non-compliance with these operating instructions will invalidate the guarantee. M-PT accepts no liability for consequential damage!

## 15. Maintenance and Service

### 15.1. General information

- To ensure the functionality and safety of the tool, it must be serviced regularly.
- Have assembly, new settings, modifications, extensions and repairs to the tool carried out exclusively by M-PT or an agency authorized by M-PT.
- The safety of the operator and the trouble-free operation of the tool can only be guaranteed if original M-PT components are used. This applies to all tool parts, accessories and spare parts.

### 15.2. Visual inspection

The user should visually inspect the following points at regular intervals:

- External damage
- Function of the moving parts
- Damage to the output and reaction arm

### 15.3. Service intervals

- The frequency of maintenance depends on the use of the tool.
- For continuous tightening up to 80% of the maximum torque, maintenance is recommended after 20.000 tightening operations.
- A service interval tailored to your application can be agreed with M-PT service engineers.

### 15.4. Repair bridge

- If you need a replacement tool to bridge the gap during repairs or maintenance, you are welcome to request a rental tool from M-PT.

#### **15.5. Calibration**

- The factory calibration of the MAD is valid for one year.
- The validity depends on the frequency of use of the tool.

#### **15.6. Contact for maintenance and repairs**



M-PT Matjeschk-PowerTools GmbH & Co. KG  
Am Sägewerk 11  
01920 Ralbitz-Rosenthal, Germany  
Tel.: +49 (0) 35796 / 9760  
E-Mail: [mail@m-pt.de](mailto:mail@m-pt.de)

## 16. Product Overview

### 16.1. Battery Torque Wrenches

- Torque range 30-15.000 Nm
- Repeatability from  $\pm 2,8$  %
- Torque/ rotation angle tightening
- Extensive data logging
- Torque Check for bolt maintenance
- Limit value monitoring



### 16.2. Electric Torque Wrenches

- Torque range 65-16.500 Nm
- Repeatability from  $\pm 2,8$  %
- Torque/ rotation angle tightening
- Extensive data logging
- Torque Check for bolt maintenance
- Limit value monitoring



### 16.3. Pneumatic Torque Wrenches

- Torque range 35-15.000 Nm
- Repeatability  $\pm 5,0$  %
- ATEX certification optionally

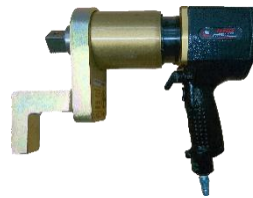

### 16.4. Hydraulic Torque Wrenches

- Torque range 110-101.600 Nm
- Repeatability  $\pm 3,0$  %
- Square- and cassette torque wrench
- 360°x180° multi-positional swivel



### 16.5. Hydraulic High Performance Pumps

- Pressure range 700-2.000 bar
- For hydraulic wrenches and clamping cylinder
- Documentation System optional



### 16.6. Software for Bolting Systems

- Dokumentation system for data collection
- Test program for checking tight bolt connections
- BoltPilot® data monitoring
- PG (CSP) worker guidance system
- ProTight™ worker guidance system

### 16.7. Transducer Technology Smart Socket™

- Absolute precision  $\pm 1,0$  %
- Graphical display of the torque curve
- Data acquisition software



### 16.8. Rental Park

- For all applications we have tools in our rental park.